

mini dunxx®



OWNERS AND SERVICE MANUAL INNOVATIVE CONCEPTS IN ENTERTAINMENT INC.

10123 MAIN STREET, CLARENCE, NY 14031

SERVICE: 1-716-759-0360

FAX: 1-716-759-0884

E-MAIL: service@icegame.com

WEBSITE: www.icegame.com

TABLE OF CONTENTS

INTRODUCTION.....	PAGE 3
• GAME FEATURES	
• GAME PLAY	
DISASSEMBLY / RE-ASSEMBLY.....	PAGE 4 –6
• GAME TOO HIGH / WIDE FOR ENTRANCE	
• ASSEMBLY DIAGRAM	
SET-UP / TESTING.....	PAGE 7 –8
MAINTENANCE.....	PAGE 9
QUICK TROUBLESHOOTING.....	PAGE 10 –11
• PROBLEMS AND SOLUTIONS	
GAME REPAIR.....	PAGE 12 –15
• MECHANICAL REPAIR	
• ELECTRICAL / ELECTRONIC REPAIR	
PARTS LISTINGS.....	PAGE 16
SCHEMATICS / WIRING DIAGRAMS.....	PAGE 17 –19
WARRANTY INFORMATION.....	PAGE 20 –21

INTRODUCTION

GAME FEATURES

MINI DUNXX™ is the newest member to our coin-op family of exciting basketball games and is designed with young children in mind. As with our FULL COURT FRENZY™ games, the basket moves, adding excitement that only this basketball game can provide.

MINI DUNXX™ utilizes state-of-the-art sound effects to add to the excitement of game play. Blending children's voices with a catchy theme song makes a combination that children really love.

The basket movement is controlled by a proven gear-motor design, along with reliable sensing and motor drive electronics.

Game set up is a snap. **JUST PLUG IN AND PLAY.**

Game design and graphics have been made specifically with young children in mind. The game height and ball return system have been made for the smaller height of youngsters. The basketballs that are used were selected because they're easy for children to pick up, and light enough for them to throw. They are also soft, so they won't cause injuries.

The game has a fully adjustable ticket dispensing feature with a ticket "cap" to allow the younger children to get an ample amount of tickets, yet prevent the older children from getting too many.

All game play features are adjustable, including: game time, coins per play, and attract mode on/off and length. It even comes with the option to allow you to stop the basket from moving, if desired.

The control panel on the game has a unique timing device. An electronic "hourglass" is utilized, being easily identified and used by young children. An oversized score display was also put in, for greater appeal. The control panel is rounded out with the use of bright colored shapes to add an eye-catching look to the game.

MINI DUNXX™ uses a rotating beacon light to add thrill to the game as points are earned. The operator can adjust how often the light comes on. The light is automatically activated during the attract mode.

Metal mesh is used on the sides and top of the game for an attractive, long, maintenance free life.

GAME PLAY

The game begins when the player inserts money into the game. When sufficient money is inserted into the game to create 1 "credit", the "Start" button will flash on the game. (The game can store up to 99 credits, and can be set to play for 1-4 coins per credit.)

Once the player presses the flashing "Start" button, the game begins. The ball gate opens to release the basketballs, and the whistle sounds to begin the game.

Once the game begins, the hourglass display starts the "sand" running, and the basket begins its first movement.

As the game progresses, the basket will move every few seconds, and stop in a new position.

As the players make baskets, the game will make a "swish" sound, or one of the four phrases: "Alright!", "Yeah!", "Awesome!", or "Great Shot!" will be heard. "New High Score!" will be heard if they break the previous record.

Just before the game ends, the ball gate will close, to capture the balls.

As the game ends, a horn sounds to signify the end of the game, and the words "Game Over" can be heard.

At this time, if your game is equipped with a ticket dispenser, tickets will be awarded. The game is then ready to be played again.

DISASSEMBLY / RE-ASSEMBLY

THIS SECTION IS PROVIDED FOR YOU IN THE UNLIKELY EVENT YOUR DOORWAY IS SMALLER THAN STANDARD.

BEFORE YOU BEGIN

IMPORTANT: FAILURE TO FOLLOW THESE DIRECTIONS CLOSELY COULD CAUSE SERIOUS DAMAGE TO YOUR GAME.

WARNING: WHEN INSTALLING THIS GAME, A 3-PRONG GROUNDED RECEPTACLE MUST BE USED. FAILURE TO DO SO COULD RESULT IN SERIOUS INJURY TO YOURSELF OR OTHERS. FAILURE TO USE A GROUNDED RECEPTACLE COULD ALSO CAUSE IMPROPER GAME OPERATION, OR DAMAGE TO THE ELECTRONICS.

DO NOT DEFEAT OR REMOVE THE GROUNDING PRONG ON THE POWER CORD FOR THE SAME REASONS AS GIVEN ABOVE. USING AN IMPROPERLY GROUNDED GAME COULD VOID YOUR WARRANTY.

TOOLS NEEDED: Before you start, you will want the following items:

- 7/16" Deep Well Socket
- 7/16" Combination Wrench
- Ratchet
- Small Allen Wrench (Supplied)
- Large Allen Wrench (Supplied)
- 1/4" Socket

REFER TO THE ILLUSTRATION IN THIS SECTION TO HELP YOU IDENTIFY THE PARTS, AND HOW THEY FIT TOGETHER.

DISASSEMBLY (GAME IS TOO HIGH FOR YOUR ENTRANCE)

NOTE: KEEP ALL HARDWARE WITH ITS RESPECTIVE PART TO PREVENT ANY CONFUSION DURING RE-ASSEMBLY.

1. Take off the mesh top enclosure by removing the 6 self-tapping screws holding it to the top of the mesh sides. Additional pilot holes are provided in the event that the holes currently being used become stripped during re-assembly. A power tool with a 1/4" socket is highly recommended if new holes need to be used.

If the game is still too high, (and/or too wide,) to pass through the entrance, refer to the following disassembly procedure.

DISASSEMBLY (GAME IS TOO WIDE FOR YOUR ENTRANCE)

NOTE: KEEP ALL HARDWARE WITH ITS RESPECTIVE PART TO PREVENT ANY CONFUSION DURING RE-ASSEMBLY.

1. Remove the mesh top enclosure as described previously.
2. Remove the clear plastic rebound guard on the front of the game (4 bolts).
3. Remove the two mesh sides (4 bolts each).
4. Remove the rear access cover (4 Screws).
5. Unplug the mate lock connector and remove the harness from the harness clips. Also, cut the tie wraps securing the harness to the rear cabinet.
6. Remove the upper rear panel (4 bolts).
7. Remove the two black tubes connecting the leg assembly to the front cabinet.
8. Remove the hardware connecting the two ball return support brackets to the bottom of the ball return (rear cabinet). It is not necessary to remove these brackets from the back of the main cabinet.
9. Disconnect the two pin connectors on the ballgate motor, remove the tape securing the harness to the ballgate motor, and cut the tie wraps holding the harness to the underside of the ball return.
10. Remove the hole plug for the latch key access hole. Carefully disconnect the two cabinets by opening the latches with the large shaped Allen wrench on both sides and lowering the rear cabinet to the floor.
11. Remove the rear leg assembly (4 bolts). (This may not be necessary.)
12. Please follow the RE-ASSEMBLY instructions to ensure proper installation.

DISASSEMBLY / RE-ASSEMBLY

RE-ASSEMBLY

1. To begin re-assembling your game, find an area to assemble the game which is close to the final location. Place something on the floor to protect the game, (or use a carpeted area).
2. Locate the Ball Return Cabinet. (This is the largest part of the game, and has an angled panel in it. The Rear Cabinet).
3. Place the ball return on its side.
4. Locate the Lower Rear Leg Assembly, and attach it to the Ball Return.
5. Position the Front Cabinet near the Ball Return. Stand the Ball Return up and set the front end of it on the two brackets located at the rear of the Main Cabinet.
6. Locate the large "L" shaped Allen wrench, commonly referred to as the 'Latch Key'. Insert it into the holes on the sides of the Ball Return. Turn the Allen wrench until the Main Cabinet and Ball Return lock together.
7. Install the hole caps into the holes on the sides of the Ball Return.
8. Re-attach the ball return support brackets to the bottom of the ball return.
9. Locate the (2) Cabinet Connecting Pipes, and install them into the game. One end of the pipe will have a threaded stud inserted into it. Screw the stud into the holes located at the bottom rear corners of the Main Cabinet.
10. Bolt the Connecting Pipes to the Lower Rear leg Assembly.
11. Locate the Backboard Upper Rear Panel, and attach it to the rear Ball Return. Be sure to install the bolts so that the nuts are at the rear of the panel.
12. Install the mesh frames to the Ball Return and Backboard Upper Rear panel. Tighten Securely.
13. Install the rebound guard to the front of the mesh frames. DO NOT OVER TIGHTEN.
14. Reconnect the harnessing to the bottom side of the ball return, (the upper rear panel), and plug in the mate lock connector.
15. Install the mesh top enclosure. If the original holes are stripped, you will need a power tool with a 1/4" socket to re-install the hardware in a new hole. OVER TIGHTENING WILL CAUSE THE SCREW HEADS TO BREAK OFF.

**YOU ARE NOW READY TO PROCEED
TO THE "SET-UP / TESTING"
SECTION OF THIS MANUAL!**

ASSEMBLY DIAGRAM

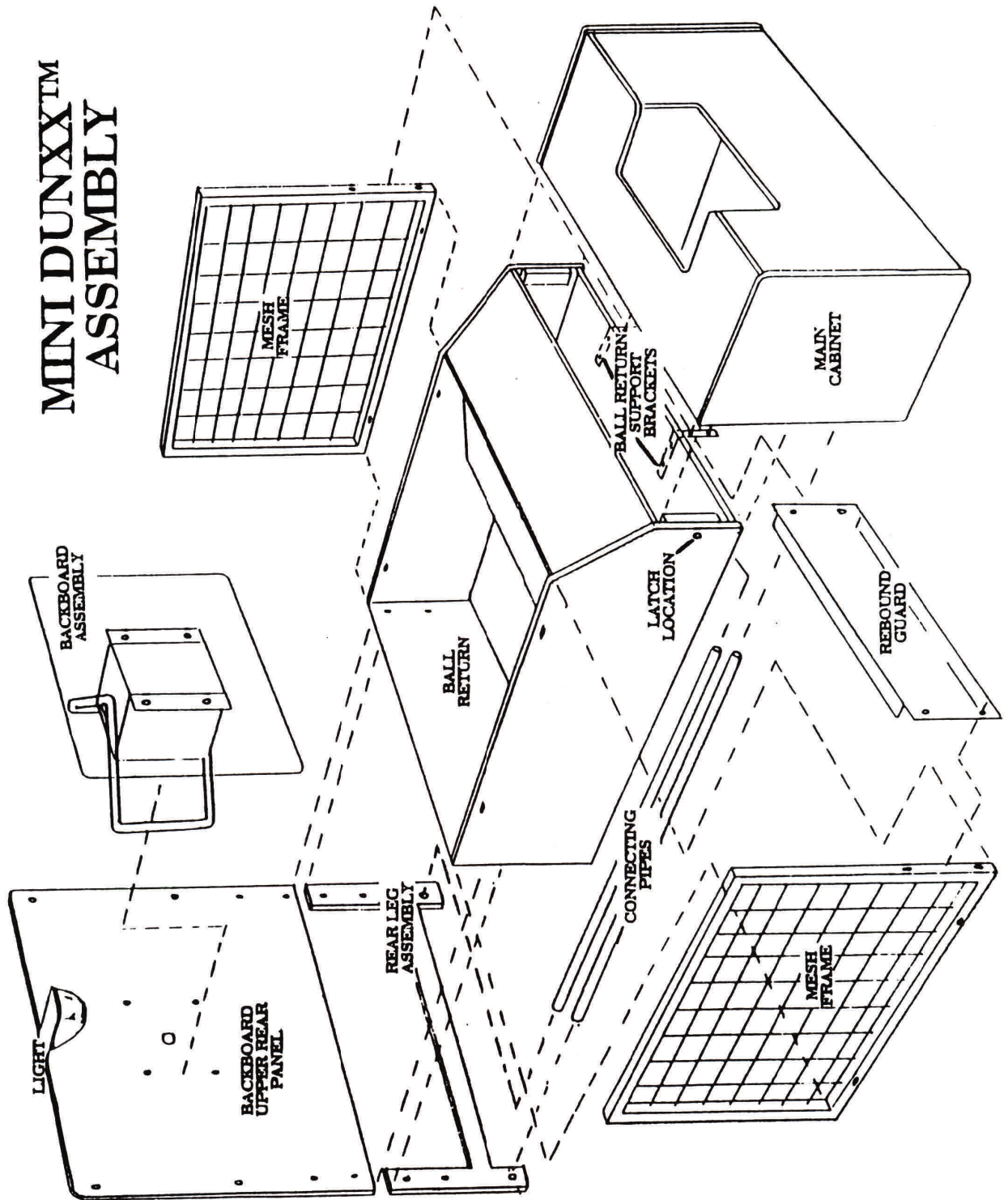

SET-UP / TESTING

SET-UP

IMPORTANT: FAILURE TO FOLLOW THESE DIRECTIONS CLOSELY COULD CAUSE SERIOUS DAMAGE TO YOU OR YOUR GAME.

BEFORE PLUGGING IN OR TURNING ON YOUR GAME, MAKE SURE THE MAIN P.C. BOARD IS SET TO THE PROPER VOLTAGE. LOOK AT THE "VOLTAGE SELECTION" SWITCH ON THE P.C. BOARD, AND VERIFY THE PROPER SETTING.

1. Plug the game into a grounded receptacle, and turn on the game power. THE POWER SWITCH IS LOCATED ON THE BACK OF THE FRONT CABINET.
2. Check for anything unusual, including strange sounds. If anything seems wrong, turn the game off IMMEDIATELY.
3. Refer to the section below to determine the proper settings for your game. After all adjustments or selections have been made, you are ready to play the game.
4. Before closing up the game, adjust the game volume by using the adjustment knob located on the Main P.C. Board.

PROGRAMMING BUTTONS

This section will give you a detailed explanation on the functions of, and operating characteristics of each of the programming buttons. Please read this section carefully to avoid problems with your game.

PROGRAMMING BUTTON (SW1)

This button is used to enter and exit the game "Programming Mode." Press this button once to enter the mode. Once in this mode, you can use the other buttons to change settings on the game. Press this button once again, anytime you wish to exit the "Programming Mode."

SELECT BUTTON (SW2)

This button is used to "select" the mode you wish to change or modify. Each push of this button will advance you to the next programming mode.

The "Hourglass" display is used to show you which mode you are in. Rows of 2 L.E.D.'s are used for each mode. Example: If 1 row of L.E.D.'s are lit, you are in mode 1. If 2 rows are lit, you are in mode 2. If 3 rows are lit, you are in mode 3, etc. The rows run from top to bottom. Press the button repeatedly to see how this works.

STEP BUTTON (SW3)

This button is used to "Step" through the various values that are set for each mode. Each push of the button will raise whatever number is displayed. These displayed values are shown in the large score display. These numbers are the numbers actually used, to change the way the game plays.

OPTION MODES

MODE 1 COINS PER CREDIT (COIN 1)

This mode determines how many coins are needed for 1 credit on the LEFT HAND COIN CHUTE. The number displayed is how many coins it needs. EXAMPLE: A setting of 2 would mean it would take 2 coins to get 1 credit or 1 game. The game default value is "1" for 1 coin per credit.

MODE 2 COINS PER CREDIT (COIN 2)

NOTE: THIS MODE IS NORMALLY RESERVED FOR USE ON 1/2 PINT FRENZY OR SPECIAL APPLICATION MINI DUNXX™ GAMES. IT IS NOT USED FOR STANDARD MINI DUNXX™ GAMES.

This mode determines how many coins are needed to create a credit on the RIGHT HAND COIN CHUTE. This mechanism is set differently, so it can be used for fractional credits. For normal use, set a "1" for this mode. If you wish to use this for a coin with a different value than that of coin mech. #1, contact the I.C.E. service department for set-up information.

SET-UP / TESTING

MODE 3 ATTRACT MODE INTERVAL

This mode controls how often the "Attract" mode comes on in this game. The Attract mode only comes on when the game is not in use. When this mode comes on, the game sounds are played and the basket moves back and forth. This mode lasts about 20 seconds. The time between Attract modes can be set in 5 minute increments from 5 to 30 minutes. Setting a "0" turns the option off. The factory default setting is "5", for 5 minutes.

MODE 4 TIME PER CREDIT

This mode controls how long each game lasts. This game can be adjusted from 20 to 45 seconds per game, in 5 second increments. The factory default setting for this option is "40" for 40 seconds.

MODE 5 JUST FOR PLAYING TICKETS

This option can be used in 2 ways. When any other ticket options are enabled, this mode can be used to give a player tickets, if they were unable to score enough points to get tickets any other way.

If this option is used with all other ticket options disabled, it can be used to payout XXX amount of tickets, regardless of game score.

This option works by setting a number that relates to how many tickets will be dispensed when one of the above scenarios are used. Setting a "0" turns this option off. The factory default setting for this option is "3", for 3 tickets.

MODE 6 POINTS PER TICKET

This mode determines how many points must be scored for EACH ticket dispensed. This can be adjusted from 1 to 20 points, in increments of 2 points. Setting a "0" turns this option off. The factory default setting is 6, for 6 points per ticket.

MODE 7 TICKET THRESHOLD

This option makes it possible to dispense tickets ONLY after the player has scored XXX amount of points. This setting is adjustable from 0-20 points.

Setting a "0" turns this option off. The factory default setting for this option is "0" for off.

MODE 8 ROTATING LIGHT INTERVAL

This mode controls how often the rotating lights come on. Every time a player scores 3 points, the game says something to the player. This option is tied into when the game says something. The game can be set for the lights to go on each time the game says something, up to every 4th time the game says something. Setting a "0" turns this option off. The factory default setting is "2", every 2nd time the game says something.

MODE 9 MAXIMUM TICKETS

This option is used to limit the amount of tickets that can be given at the end of the game. This option is used to prevent older, more skilled children or adults, from getting too many tickets from the game. This limit can be set from 1-99 tickets. Setting a "0" turns this option off. The factory default setting for this option is "25" for a 25 ticket limit.

MODE 10 BASKET ON / OFF

This option is used to turn the movement of the basket on or off. It may be desirable under certain circumstances, to keep the basket from moving for extremely young children. This option will allow you to do this. We do however, recommend that you keep the basket moving for greater player appeal. Setting a "0" turns the basket off. The factory default setting for this option is "1" for on.

MODE 11 ALARM MODE ON / OFF

This option allows the AUDIBLE TAMPER ALARM to be turned on or off. Select a "0" to turn the alarm mode off. Select a "1" to turn the alarm mode on. The factory default setting is "1".

TESTING

After set-up is complete, play a few games to verify everything is working correctly. Pay special attention to the Ball Gate, Basket Movement, Scoring, and Score Displays.

MAINTENANCE

GENERAL MAINTENANCE

The MINI DUNXX™ Basketball game has been engineered to be as maintenance free as possible. There are, however, a few things you can do to keep your game in top operating condition at all times. Following the guidelines below will ensure a long, trouble-free life for your game.

BASKETBALLS

The basketballs in this game should always be kept inflated to the proper size. If the balls are too big or small, they will not work properly in the game. Use the inflation gauge supplied to keep the balls inflated to the proper diameter.

The amount of balls is also VERY IMPORTANT to play value in the game. Always keep at least 8 balls in the game at all times. This ensures there are always enough available during the game. It would be a good idea to keep extra balls available to replace worn or damaged balls. The balls can be obtained easily through our Service Department at (716) 759-0360.

TICKET DISPENSER

The Ticket Dispenser on the game is relatively trouble-free, however cleaning the unit occasionally from bits of ticket dust will keep the unit working reliably. Use high-pressure air, (such as from an aerosol can,) to blow dust build-up from the mechanism and optical sensor. Clean the drive wheels with an isopropyl alcohol,

COIN MECHANISM

The coin mechanism occasionally needs to be cleaned to remove build-up of dirt and debris.

To clean mechanism, remove the coin mechanism from the game and clean it with soapy water. Dry it thoroughly and re-install. Test for proper operation.

GAME CABINET AND GRAPHICS

The game should be cleaned occasionally to keep it bright and attractive looking. Clean the cabinet sides with a good cleaner such as “Fantastik”® or “409”® and a soft rag. Follow cleaning with a furniture polish, such as Pledge®.

NOTE: DO NOT USE ALCOHOL, THINNERS OF ANY KIND, OR PINBALL PLAY FIELD CLEANERS ON ANY OF THE CABINET SURFACES ESPECIALLY THE DECALS.

IF YOU HAVE ANY QUESTIONS OR COMMENTS REGARDING INSTALLATION OR PROPER FUNCTION OF YOUR GAME, PLEASE CALL OUR SERVICE DEPARTMENT AT:

I.C.E. SERVICE DEPARTMENT

716-759-0360

NORMAL BUSINESS HOURS ARE:

MONDAY – FRIDAY, 9:00 AM TO 6:00 PM EST

QUICK TROUBLESHOOTING

PROBLEM	PROBABLE CAUSE	SOLUTION
NO GAME POWER	ON-OFF SWITCH ON THE GAME IS TURNED OFF BLOWN A.C. POWER FUSE GAME NOT PLUGGED IN OR CORD DAMAGED BAD TRANSFORMER TRANSFORMER HARNESSING NOT CONNECTED	TURN POWER ON REPLACE WITH PROPER FUSE CHECK POWER CORD CHECK PROPER VOLTAGES CHECK HARNESS
GAME WILL NOT TAKE MONEY OR GIVE CREDITS CORRECTLY	BAD COIN SWITCH GAME CREDITS SETTING INCORRECT BAD COIN MECHANISM LOOSE OR DAMAGED HARNESSING BAD MAIN P.C. BOARD	CHECK W / METER AND REPLACE CHECK MANUAL AND SET PROPERLY ADJUST OR REPLACE CHECK W / METER AND REPAIR REPAIR OR REPLACE MAIN BOARD
BALLS GET STUCK IN GAME	BALLS INFLATED TO WRONG SIZE BALL GATE MOTOR BROKEN BALL GATE DRIVER P.C. BOARD DEFECTIVE BAD OR DISCONNECTED HARNESSING BAD MAIN P.C. BOARD	USE INFLATION GAUGE SUPPLIED REPAIR OR REPLACE MOTOR REPLACE DRIVER P.C. BOARD REPAIR OR REPLACE HARNESSING REPAIR OR REPLACE MAIN BOARD
GAME WILL NOT START WHEN PROPER CREDITS ARE IN GAME	BAD START BUTTON MICRO SWITCH BAD START BUTTON HARNESSING BAD MAIN P.C. BOARD GAME SET IN TEST MODE	REPLACE MICRO SWITCH TEST AND REPAIR HARNESSING REPAIR OR REPLACE MAIN BOARD EXIT TEST & PROGRAMMING MODE
NO GAME SOUND	BAD OR SHORTED SPEAKER BAD SPEAKER HARNESSING GAME SOUND TURNED OFF	REPLACE SPEAKER TEST AND REPAIR HARNESSING ADJUST VOLUME
NO SCORING (NO SCORES ADDED)	BAD TRANSMITTER P.C. BOARD (NO TEST LEAD ON RECEIVER) BAD RECEIVER P.C. BOARD (TEST LIGHT DOESN'T CHANGE) BAD SENSOR HARNESSING BAD MAIN P.C. BOARD	REPLACE TRANSMITTER REPLACE RECEIVER CHECK AND REPAIR HARNESSING REPAIR OR REPLACE MAIN BOARD
SCORES INTERMITTENTLY	BAD OR LOOSE HARNESSING 1/2 OF RECEIVER P.C. BOARD BAD (TEST EACH RECEIVER) NET TIE WRAPPED IN FRONT OF I.R. TRANSMITTER	REPAIR OR REPLACE HARNESSING REPAIR OR REPLACE P.C. BOARD MOVE NETTING FROM SENSOR
NO SCORING (SCORES BUT NOT DISPLAYED)	BAD OR INTERMITTENT DISPLAY HARNESSING BAD SCORE DISPLAY BAD MAIN P.C. BOARD	REPAIR HARNESSING REPAIR / REPLACE SCORE DISPLAY REPAIR OR REPLACE MAIN BOARD
BASKET DOES NOT MOVE CORRECTLY	BAD ROTARY MOTOR LOOSE OR WEAK CLUTCH BAD OR IMPROPERLY ALIGNED ENCODER P.C. BOARD BAD ENCODER DECAL BAD HARNESSING BAD MAIN P.C. BOARD GAME OPTION SET TO NON-MOVING VERSION	REPLACE MOTOR TIGHTEN OR REPLACE CLUTCH ADJUST OR REPLACE ENCODER P.C. BOARD CHECK FOR SCRATCHES & REPLACE CHECK AND REPAIR HARNESSING REPAIR OR REPLACE MAIN BOARD CHANGE PROGRAM SETTING
GAME DOES NOT DISPENSE TICKETS PROPERLY	OUT OF TICKETS LOOSE OR BAD HARNESSING BAD TICKET DISPENSER TICKETS JAMMED BAD MAIN P.C. BOARD TICKET OPTION NOT SET CORRECTLY	ADD TICKETS TO DISPENSER CHECK AND REPAIR HARNESSING REPLACE DISPENSER CLEAR TICKET JAM REPAIR OR REPLACE MAIN BOARD ADJUST OPTIONS CORRECTLY
ROTATING LIGHTS DO NOT WORK PROPERLY	BAD BULB IN ROTATING LIGHT BAD MOTOR IN ROTATING LIGHT BAD GAME OR LIGHT HARNESSING HARNESSING NOT PLUGGED IN BAD MAIN P.C. BOARD	REPLACE LIGHT BULB REPLACE ROTATING LIGHT CHECK AND REPAIR HARNESSING CHECK CONNECTIONS REPAIR OR REPLACE MAIN BOARD

QUICK TROUBLESHOOTING

PROBLEM	PROBABLE CAUSE	SOLUTION
NO GAME FUNCTIONS (GENERAL)	BAD A.C. OR D.C. FUSES CONNECTORS BAD OR NOT FULLY INSTALLED SHORTED COMPONENT IN GAME	CHECK AND REPLACE FUSES CHECK CONNECTORS CHECK ALL PCB'S AND HARNESSSES
START BUTTON WILL NOT FLASH	BAD LIGHT BULB BAD OR INTERMITTENT HARNESSING BAD MAIN P.C. BOARD	REPLACE LIGHT BULB CHECK AND REPAIR HARNESSING REPAIR OR REPLACE MAIN BOARD
BASKETBALL LIGHTS WILL NOT LIGHT	BAD LIGHT BULB BAD OR INTERMITTENT HARNESSING BAD MAIN P.C. BOARD	REPLACE LIGHT BULB CHECK AND REPAIR HARNESSING REPAIR OR REPLACE MAIN BOARD
ALARM SOUNDS FREQUENTLY	BAD I.R. TRANSMITTER BAD I.R. RECEIVER BAD MAIN P.C. BOARD NETTING IN FRONT OF TRANSMITTER BAD OR SHORTED HARNESSING	REPLACE I.R. TRANSMITTER REPLACE I.R. RECEIVER REPAIR OR REPLACE MAIN BOARD MOVE NETTING FROM SENSOR CHECK AND REPAIR HARNESSING
ATTRACT MODE DOES NOT WORK CORRECTLY	GAME OPTIONS SET IMPROPERLY	RESET GAME PROGRAMMING

MECHANICAL REPAIR

OPERATIONAL BACKGROUND

The following will outline the basic operating principles of the MINI DUNXX™ Basketball game.

The movement of the MINI DUNXX™ Basketball game hoop is operated through a gear motor control that moves the basket assembly back and forth. This is a 12 volt gear motor that has power to it applied and reversed by the game electronics.

It is useful to know that power to the gear motor is chopped through the game software to allow software control of the motor speed. The motors are run at a 50% duty cycle. This is important to know if the circuitry is being analyzed by oscilloscope. Direction of the gear motor is achieved by reversing power. The electronics have built-in dynamic braking to stop the motor quickly.

The positioning of the basket assembly is accomplished through an optical encoding system. The system uses a decal with alternating reflective and non-reflective surfaces as a medium for the optic L.E.D.'s. A system of 3 L.E.D.'s are used to determine position of the backboard. The high / low pulses sent out by the encoder P.C. Board are received and interpreted by the Main P.C. Board. These signals are then converted to commands by the software, depending upon game conditions. This type of operating system allows limitless control by software design, allowing easy repairs of the game in the field, thus avoiding expensive and sometimes difficult mechanical field modifications.

The game also uses reliable optical detectors for ball sensing. This creates a sensing system that has a much longer life span than its mechanical counterparts. The Receiver P.C. Board receives a pulsed light beam from the Emitter P.C. Board at a specified frequency. This helps eliminate background electronic noise that could cause interference. The receiver L.E.D.'s incorporate automatic gain control to consistently adjust to changing environmental circumstances.

The ball gate system on the game is operated by a rotational gearbox. The Driver P.C. Board flip-flops incoming D.C. power to operate the unit. Operating the D.C. power with one polarity opens the ball gate. Reversing polarity causes the ball gate to close. The reversing of current is accomplished through a combination of hardware and software from the game's Main P.C. Board.

The following sections will give you detailed information on repair, replacement, and adjustment of the game's components.

MECHANICAL REPAIR

WARNING: ALWAYS REMOVE POWER TO THE GAME, BEFORE ATTEMPTING ANY SERVICE, UNLESS NEEDED FOR SPECIFIC TESTING. FAILURE TO OBSERVE THIS PRECAUTION COULD RESULT IN SERIOUS INJURY TO YOURSELF OR OTHERS.

BALL GATE

BALL GATE REMOVAL

Ball gate removal is accomplished in the following order:

1. Turn off all power to the game and remove the A.C. Power Cord.
2. Climb into the game and unplug the 2 pin connectors that are attached to the Ball Gate Driver P.C. Board.
3. Cut the tie wrap that secures the harness to the Ball Gate Motor.
4. Loosen the (2) Allen Head screws that are on the Ball Gate on the opposite side of the motor.
5. Push the shaft at the end of the ball gate into the gate, and the entire assembly can now be removed.

PLEASE NOTE: THE THREAD LOCKING COMPOUND USED TO SECURE THE SHAFT TO THE BALL GATE MAY PREVENT THE SHAFT FROM SLIDING INTO THE BALL GATE EASILY. USE A PAIR OF PLIERS (IF NECESSARY) TO TURN THE SHAFT IN TO THE BALL GATE.

THE BLACK VELCRO POSITIONED ON THE END OF THE BALL GATE IS USED TO PREVENT THE OPTICAL ENCODER CLOSEST TO THE MOTOR SHAFT FROM REFLECTING ON TO THE END OF THE BALL GATE, WHEN IN THE CLOSED POSITION. THIS MUST BE LOCATED RIGHT UP AGAINST THE MOTOR SHAFT FOR THE BALL GATE MECHANISM TO WORK PROPERLY. PLEASE DO NOT REMOVE THIS VELCRO STRIP FROM THE SHAFT, EXCEPT TO REPLACE IT.

MECHANICAL REPAIR

BALL GATE DRIVER P.C. BOARD REMOVAL

1. Loosen the (2) Allen Head screws that hold the Ball Gate to the Ball Gate Motor.
2. Remove the (2) screws and star washers that hold the P.C. Board to the motor.
3. Unsolder the wires from the motor. **NOTE:** REMEMBER WHICH WAY THE WIRES ARE ATTACHED TO THE MOTOR.
4. Check the motor for proper operation. This can be done by hooking it up to any 5-12 volt D.C. power source and checking for smooth rotation without any binding or skipping.
5. Check the Ball Gate Driver P.C. Board for proper operation. (For details on testing, refer to the electronics section of this manual.)

IMPORTANT: WHEN RE-ASSEMBLING THE BALL GATE ASSEMBLY, IT IS NECESSARY TO KEEP A SPACING OF 3/16" TO 1/4" BETWEEN THE BALL GATE AND THE EDGE OF THE OPTICAL ENCODERS. IF THESE ARE SPACED IMPROPERLY, THE SENSORS WILL NOT WORK PROPERLY AND THE BALL GATE WILL EITHER CONTINUE TO ROTATE OR STOP IN STRANGE POSITIONS.

BE SURE THE OPTICAL ENCODERS FACE STRAIGHT UP ON THE P.C. BOARD, AND ARE NOT BENT OVER TOWARDS THE MOTOR SHAFT. IF THE ENCODERS ARE BENT TOWARDS THE SHAFT, THE BALL GATE WILL CONTINUE TO RUN.

BACKBOARD SERVICE ENCODER P.C. BOARD

The Encoder P.C. Board may be serviced by removing the backboard from the game.

1. Remove the backboard from the game by removing the (4) Phillips head bolts that hold the backboard to the Motor Housing.
2. Remove the (2) hex spacer nuts that hold the Encoder P.C. Board to the Motor Housing.
3. Remove the connector from the Encoder P.C. Board. Please be sure the connector is installed the same way when re-assembling the game.

MOTOR HOUSING REMOVAL

It is necessary to remove the Backboard to service the Gear Motor or Clutch Assembly.

1. Remove the (4) Phillips head bolts that hold the Motor Housing to the Backboard.

DO NOT PULL THE ASSEMBLY AWAY FROM THE REAR OF THE GAME UNTIL THE HARNESSING HAS BEEN DISCONNECTED.

MOTOR OR CLUTCH REMOVAL

1. Unplug the (3) single pin connectors for the score sensor. (Make sure when you re-connect them, that you match the wire colors).
2. Remove the (3) Allen Head screws that hold the Backboard Mounting Bracket to the Clutch.
3. Remove the (1) Allen Head Shoulder Bolt that holds the Backboard Bearing to the Motor Housing.
4. Slide the Backboard Mounting Bracket off of the Motor Housing and Clutch.
5. If removing the Clutch, remove the (2) Allen Head Set Screws that hold the Clutch to the motor shaft, as well as the "E" clip. Pull the Clutch off of the motor shaft using a twisting motion.

ELECTRONIC REPAIR

The following section will describe repair procedures and trouble shooting hints for the game electronics.

Please read the section "Operational Background" located in the "Mechanical Repair" section of this manual. This will give you a good idea of the game's overall operating parameters.

WARNING: EXERCISE CAUTION WHENEVER WORKING WITH ELECTRONICS, AS THEY CAN BE VERY SUSCEPTIBLE TO DAMAGE FROM SHORT CIRCUITING OR PHYSICAL ABUSE. ALWAYS UNPLUG THE GAME WHEN WORKING ON HIGH VOLTAGE AREAS OF THE GAME, SUCH AS THE TRANSFORMER OR MONITOR.

USE EXTREME CAUTION WHEN USING VOLT METERS TO DO CIRCUIT CHECKS IF THE GAME POWER HAS BEEN LEFT ON.

WHEN USING A VOLT METER, BE SURE IT IS SET TO THE CORRECT VOLTAGE OR RESISTANCE RANGE, BEFORE USING. THIS CAN PREVENT POSSIBLE DAMAGE TO THE P.C. BOARD OR MISDIAGNOSIS.

ALWAYS REMOVE POWER TO THE GAME WHEN PLUGGING OR UNPLUGGING P.C. BOARDS.

IT IS NECESSARY TO USE I.C.E. REPLACEMENT PARTS TO CONTINUE WARRANTY COVERAGE. USE OF NON-I.C.E. APPROVED PARTS WILL NOT ONLY VOID YOUR WARRANTY, BUT COULD CAUSE SERIOUS HARM TO THE GAME OR CAUSE SERIOUS BODILY INJURY.

IF YOU HAVE ANY QUESTIONS REGARDING REPAIR AFTER READING THIS SECTION, CALL OUR SERVICE DEPARTMENT AT (716) 759-0360 BEFORE PROCEEDING.

FUSES

Fuses are the first thing that should be checked when the game either appears not to work, or appears to work incorrectly.

There are 3 fuses in this game. The fuses are located on the Main P.C. Board. 2 of the fuses are for low voltage D.C., and are exposed on the P.C. Board. One of the fuses is for high voltage A.C., and is in an insulated housing.

To check or service the fuses, FIRST REMOVE THE POWER CORD FROM THE WALL OUTLET. FAILURE TO REMOVE THE POWER CORD

COULD RESULT IN SERIOUS INJURY OR DEATH. Using a small flat blade screwdriver, pry the fuse from the fuse holder, or turn the cap off of the fuse holder, and remove the fuse.

NOTE: ALWAYS TEST THE FUSE WITH A VOLT METER, EVEN IF THE FUSE LOOKS GOOD. THERE SHOULD BE NO RESISTANCE NOTED WHEN TESTING FOR CONTINUITY. THIS TEST MUST BE PERFORMED, AS CERTAIN TYPES OF FUSES HAVE THE POTENTIAL TO ONLY BLOW PARTIALLY, GIVING THE APPEARANCE OF WORKING FINE, UNTIL A LOAD IS PLACED ON THEM.

Replace the Main P.C. Board fuses with the original type and value. USE SLO-BLO MDQ TYPE fuses only. Other types of slo-blo fuses may cause strange problems with the game.

CHANGING A.C. VOLTAGES

Voltages are easily changed on the Main P.C. Board. A convenient voltage selection switch is mounted towards the center of the board. Be sure of the voltage you require, and simply slide the switch to the correct voltage setting.

MAIN P.C. BOARD

IMPORTANT: BEFORE REMOVING THE MAIN P.C. BOARD FOR SERVICE OR REPLACEMENT, RECORD ALL INFORMATION REGARDING CUSTOM OPTION SETTINGS, SO THESE SETTINGS CAN BE RE-INSTALLED LATER IF NECESSARY.

The Main P.C. Board is located inside the Main Cabinet beneath the ball tray.

When performing service on the Main P.C. Board, it is a good idea to remove the board when replacing even socketed or snap-in components. This can avoid any possible costly errors that may occur otherwise.

Remove the Main P.C. Board in the following manner:

1. Remove all A.C. Power to the game. (REMOVE THE POWER CORD FROM THE A.C. RECEPTACLE.)
2. Disconnect all Mate-Lock connectors from the game.

ELECTRONIC REPAIR

3. Remove the (6) plastic nuts that retain the P.C. Board to the mounting bracket.
4. Carefully remove the Main P.C. Board
5. Re-assemble in reverse order.

BALL SENSORS

It is not necessary to remove the hoop from the backboard to service the ball sensors. This operation can be easily accomplished while still on the game.

1. Remove power to the game to prevent damage to the electronics when connecting or disconnecting game harnessing.
2. Try to determine which sensor is at fault, Emitter or Receiver. This can be determined as follows:
 - a) If pilot L.E.D. on receiver is lit brightly, and intensity doesn't change regardless of blocking the Emitter, the Receiver is probably bad.
 - b) If pilot L.E.D. flashes when the receiver is blocked, but score is not seen during game play and harnessing proves good, the Receiver is probably bad.
 - c) If pilot L.E.D. is lit dimly, or strobes dimly, the Emitter is probably bad.

To change the Emitter:

- a) Remove the Emitter and Receiver covers.
- b) Unplug the Emitter harness from the Receiver (closest to the backboard.)
- c) Remove the Emitter harness from the hoop. REMEMBER HOW TO ROUTE THIS HARNESS WHEN INSTALLING THE NEW EMITTER.
- d) Remove the plastic retaining nuts.
- e) Re-assemble in reverse order.

To change the Receiver:

- a) Remove the receiver cover.
- b) Remove the (3) single pin connectors from the motor harness to the Receiver.
- c) Unplug the Emitter harness from the Receiver.
- d) Remove the plastic nuts that retain the Receiver to the housing.
- e) Re-assemble in reverse order.

REMEMBER TO CONNECT THE HARNESSING TO THE STRAIN RELIEF TO KEEP THE HARNESSING FROM FALLING DOWN INTO AN AREA WHERE THE BALLS COULD HIT IT.

SCORE DISPLAY P.C. BOARD

The score display can be serviced as follows:

- a) Remove all A.C. power from the game.
- b) Remove the (3) Allen Head screws that hold the retaining bracket for the score display, and remove the bracket.
- c) Lift the control panel containing the score display from the game.
- d) Disconnect the harnessing from the score display.
- e) Remove the (8) plastic nuts that retain the display to the control panel.
- f) Re-assemble in reverse order.

PARTS LISTINGS

MECHANICAL PARTS

MD1001	Control Panel Housing
MD1002	Control Panel Retainer
HP1003	Backboard Mounting Bracket
HP1004	Motor Housing
HP1006	Cabinet Connecting Pipes
MD1007	I.R. Emitter Cover
MD1008	I.R. Receiver Cover
HP1009	Motor Shield
MD1011	Mesh Frame
HP1023	Ball Gate Shaft
BB1034	Clutch (XIC-1803)
MD1039A	Hoop, Fabricated & Painted
HP3001	Basketballs
MD3002	Backboard, Printed & Fabricated
HP3003	Ball Gate Bearing
MD3005	Control Panel, Printed & Fabricated
BB3008	Basketball Net
HP3013	Backboard Mtg. Bracket, Nylon Plastic
MD3014	Main Cabinet
MD3015	Ball Return Cabinet
MD3017	Rebound Guard
FP3057	Upper Flipper Cover
5001	Coin Door, Over - Under
PC50507	Speaker Grill
MD1022	Ball Gate

DECALS & GRAPHICS

HP7001	Programming Decal
MD7001	Decal (MD Cabinet Top)
MD7002	Decal (MD "ICE")
MD7003	Decal (MD Rear Cabinet)
MD7004	Decal (MD Front Cabinet)
HP7010	Encoder Decal (for rotation)
MD9001	Service Manual

HARDWARE

3052	Hole Plug
6103	Latch (2-67-0055-02)
6104	Latch Receptacle (2-67-0002-02)
6105	Latch Tool (2-75-0059-02)
655s	#8 x 5/8" Square Drive Screw
PC60601	1/4-20 x 5/8" Allen Head Bolt, Black
3036	Black Plastic Washer
6106	5/16 x 1/2" Shoulder Bolt
PC60641	6-32 x 5/8" Plastic Hex Spacer
PC60642	6-32 x 3/8" Plastic Hex Spacer
PC60643	6-32 x 1/4" Plastic Hex Spacer
644P	6-32 x 1/2" Plastic Hex Spacer
PC60631	1/4-20 Cabinet Insert
6051	1/4-20 x 1" Phillips Head Bolt
MD3027	1" x 2" Black Tube Cap

ELECTRICAL PARTS

HP2005	Basketball Push Button w/ "Start"
2007	Speaker
MD2008X	Ball Gate Motor
HP2009X	Rotary Motor
PC20224	12volt Counter
BT2027X	20Ft. Line Cord
2364	12volt Fan

ELECTRONIC PARTS

HP2000X	Display P.C. Board
HP2001X	Main P.C. Board
MD3004X	Net Sensor Prior to April 2007
E00210MDX	Net Sensor After March 2007
BB2014X	FCF Position Encoder P.C. Board
HP2029X	Ball Gate P.C. Board

zone	tr	description	date	approved

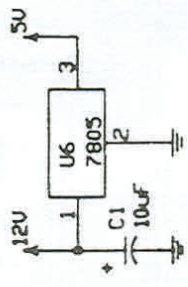
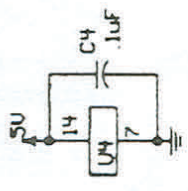
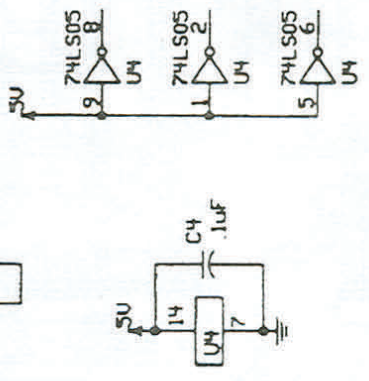
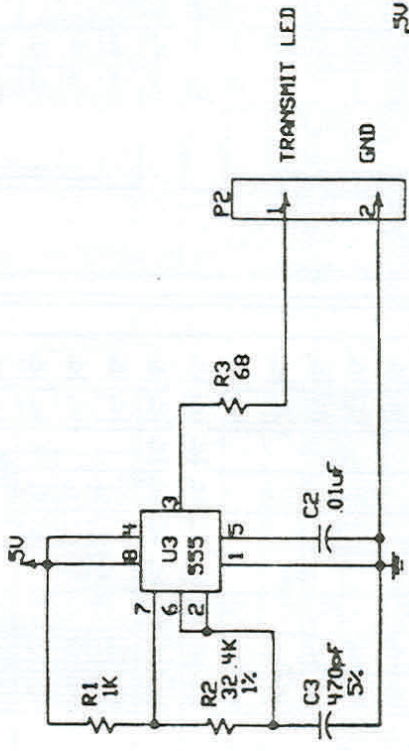
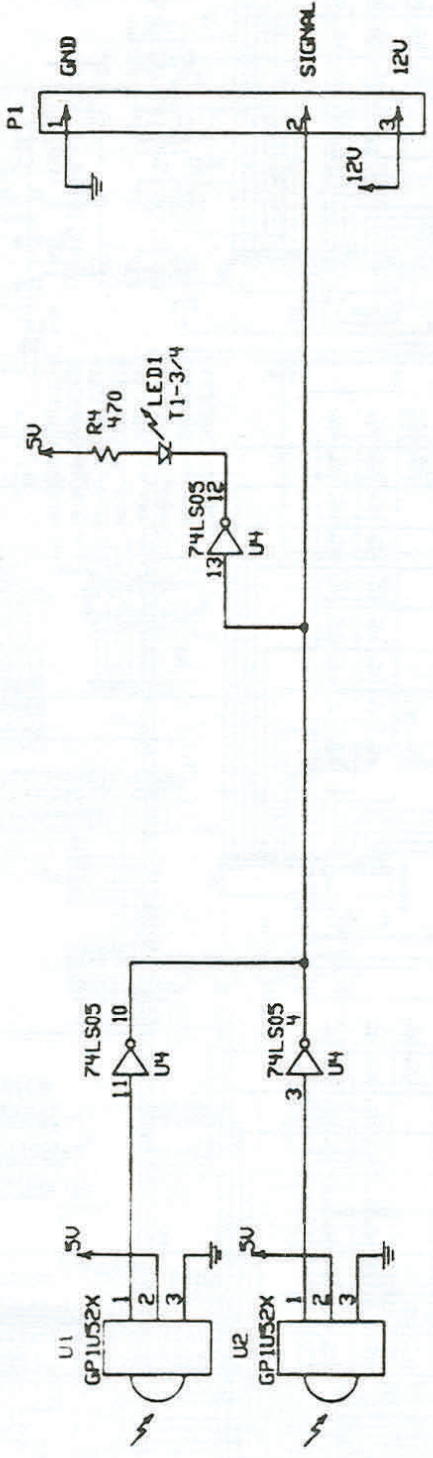

REV 1

I.C.E. Inc.

FULL FRENZY JR.
BASKET SENSOR
SCHEMATIC

prepared SPD 11-93
Checked
engineer GHD 11-93

sizeCode id drawing no.
A

scale MA

sheet of 1

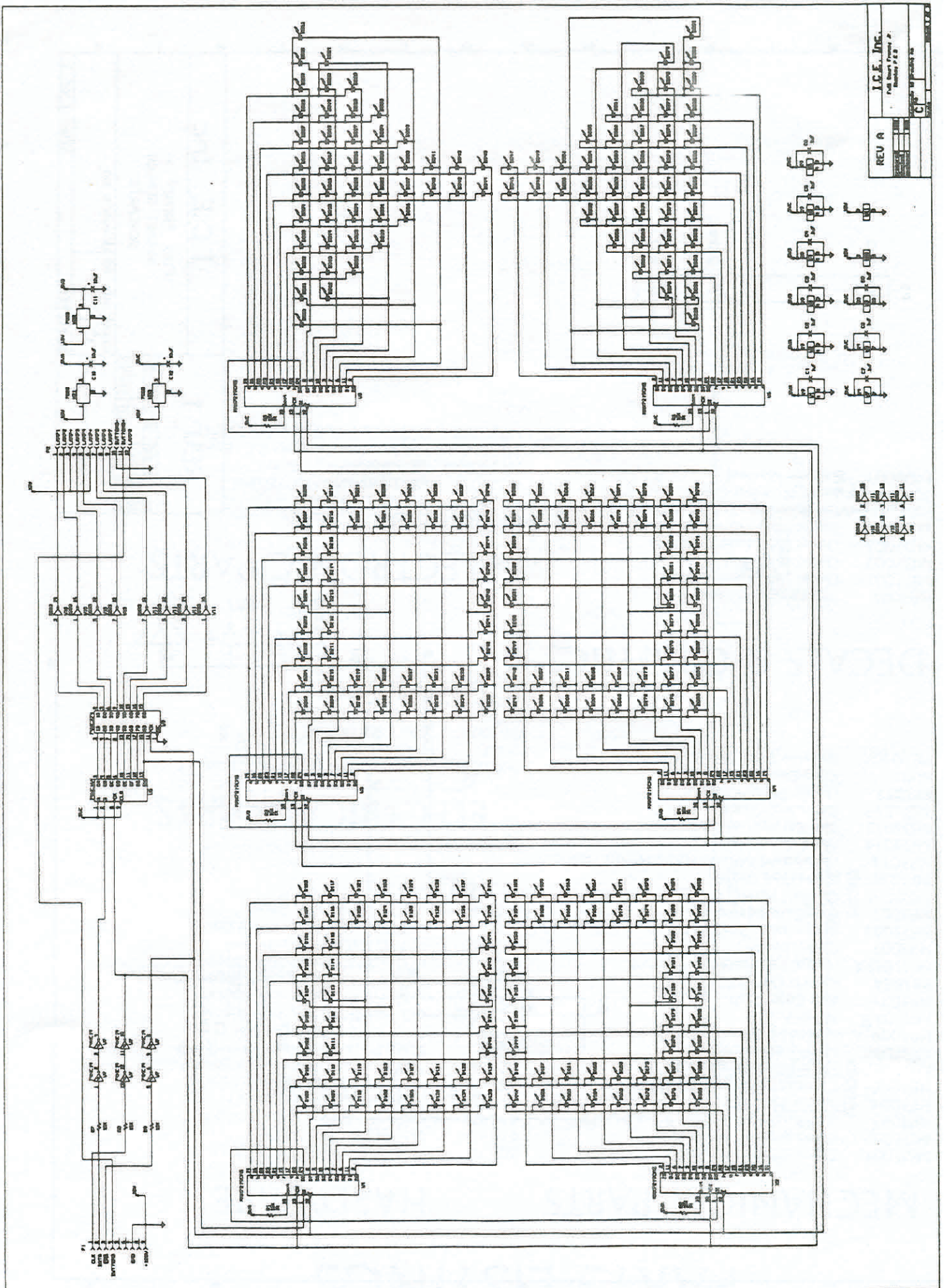

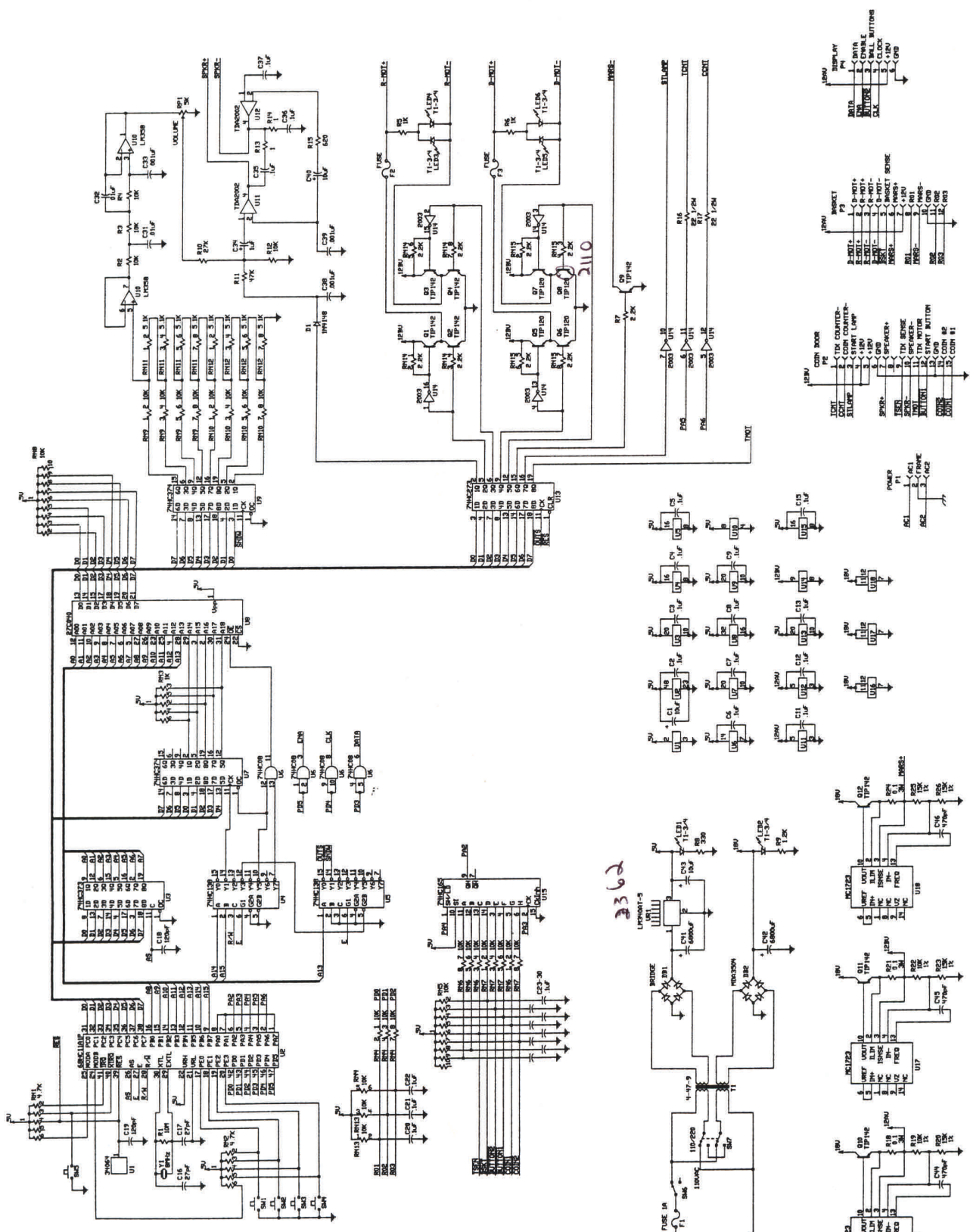

U13
 U14
 U15

2936

WARRANTY

I.C.E warrants all components in the **MINI DUNXX™** game to be free of defects in materials and workmanship for a period of ninety days from the date of purchase.

This warranty does not cover items damaged due to normal wear and tear, subjected to abuse, improperly assembled by the end user, modified, repaired, or operated in a fashion other than that described in the service manual.

If your **MINI DUNXX™** game fails to conform to the above-mentioned warranty, I.C.E.'s sole responsibility shall be at its option to repair or replace any defective component with a new or remanufactured component of equal to or greater O.E.M. specification.

I.C.E. will assume no liability whatsoever, for costs associated with labor to replace defective parts, or travel time associated therein.

I.C.E.'s obligation will be to ship free of charge, replacement parts by domestic U.P.S. Ground, U.S. mail, or other comparable shipping means. Any express mail or overnight shipping expense is at the cost of the purchaser.

Products will be covered under warranty only when:

- The serial number of the game with the defective parts is given.
- The serial number of the defective part, if applicable, is given.
- Defective parts are returned to I.C.E., shipping pre-paid, in a timely fashion, if requested by I.C.E.
- A copy of the sales receipt is available as proof of purchase upon request of I.C.E.

I.C.E. distributors are independent, privately owned and operated. In their judgment, they may sell parts or accessories other than those manufactured by I.C.E. We cannot be responsible for the quality, suitability, or safety of any non-I.C.E. part, or any modification, including labor, which is performed by such a distributor.



WARRANTY

ICE Inc warrants that all of its products will be free from defects in material and workmanship.

When placing a warranty request, please be prepared to provide the following information:

- Serial Number of Game or Bill of Sale
- Machine Type
- A Detailed Description of the Equipment Fault Symptoms

ICE product, including Cromptons, Sam's Billiards, Uniana and Bell Fruit is warranted as follows:

- 180 days on the Main PCB and Computers
- 180 days on Motors
- 90 days on all other components (i.e. DBV's, Ticket Dispensers, etc)
- 30 days on repaired items
- 3 years on all Crane Harnessing
- 9 Months on Printers

ICE Inc shall not be obligated to furnish a warranty request under the following conditions:

- Equipment has been subjected to unwarranted stress through abuse or neglect
- Equipment has been damaged as a result of arbitrary repair/modification attempts
- Equipment that has failed through normal wear and tear

ICE Inc will assume no liability whatsoever for costs associated with labor to replace defective parts or travel time associated therein.

All defective warranty covered components will be replaced with new or factory refurbished components equal to OEM specifications. ICE Inc will cover all domestic UPS ground, or comparable shipping means, freight costs during the warranty period. Expedited shipments are available for an additional charge.

Defective parts are returned to ICE Inc, at the customer's expense, in a timely fashion.

ICE distributors are independent, privately owned and operated. In their judgment, they may sell parts and/or accessories other than those manufactured by ICE Inc. We cannot be responsible for the quality, suitability or safety of any non-ICE part, modification (including labor) that is performed by such a distributor.

I.C.E. Parts/Service Dept.
Innovative Concepts in Entertainment
10123 Main St.
Clarence, NY 14031
Phone #: (716) - 759 - 0360
Fax #: (716) - 759 - 0884